

"BUMPER TO BUMPER" LIMITED LIFETIME WARRANTY

Each Traveler Guitar instrument is warranted to be free from defects in materials and workmanship for as long as it is owned by the original retail purchaser except strings, tuning machines, frets, switches, electronic components, jacks, pickguards, and plated surfaces, which are warranted for a period of three (3) years from the date of the original purchase. The warranty is only eligible to the original owner, and the guitar must have been purchased from an authorized Traveler Guitar dealer.

Traveler Guitar will replace or repair, at its discretion, any Traveler Guitar instrument or part thereof, which is found by Traveler Guitar to be defective. Traveler Guitar reserves the right to use original replacement materials or materials of similar design at the time of the repair.

To become eligible for warranty service, the original purchaser must:

1. Submit a completed warranty card or online registration form to Traveler Guitar.
2. Contact Traveler Guitar to obtain a return authorization code before returning any instrument for service.
3. Provide proof of purchase with all requests for warranty service (original receipt.)
4. Be responsible for all freight and transportation to and from Traveler Guitar's facility in Redlands, CA.

The Traveler Guitar Warranty does not cover:

1. Instruments that have been altered or modified in any way, including altered or removed serial numbers.
2. Instruments that have been subjected to extreme temperature or humidity, chemicals, synthetic materials or other abnormal conditions.
3. Wear, discoloration or marks on the finish, metal plating or wood grain of the guitar.
4. Setups, adjustments, tonal characteristics or routine maintenance of any kind.
5. Instruments that have been damaged due to misuse or neglect.
6. Normal wear and tear to hardware including: strings, tuning machines, frets, switches, electronic components, jacks, pickguards, and plated surfaces.

Please contact us first to resolve any warranty issues.

WARRANTY INQUIRIES

Traveler Guitar
ATTN: Warranty Department
440 Business Center Court
Redlands, CA 92373 USA
(909) 307-2626
travel@travelerguitar.com



REDLANDS DREADNOUGHT User Guide

THANK YOU FOR PURCHASING A REDLANDS DREADNOUGHT GUITAR

Traveler Guitar is the industry's leading manufacturer of full-scale, travel-sized instruments. Most travel guitars sacrifice playability for portability—but at Traveler Guitar, we believe players need both. Since 1992, we have designed full-scale acoustic and electric travel guitars, offering a wide variety of solutions for players on the go.

The Redlands Dreadnought you hold in your hands represents a revolution in travel guitar design—an acoustic guitar that features advanced built in electronics. Its unique design makes it compact for travel and small enough to fit in an airline overhead compartment, yet it has a full-size neck.

Join our community on Instagram and Facebook where we routinely share images of our customers with their Traveler Guitars! Be sure to tag us and use hashtag #travelerguitar when posting.



CONSTRUCTION

The proprietary Streamline™ tuning system allows for easy, accurate, right-hand tuning. The tuning system is mounted on the endblock, leaving the guitar's top free to vibrate. In addition, the Redlands Dreadnought guitars are built with a modified bracing pattern designed to produce greater volume and sustain.

Built into the guitar is a pickup & preamp with 3-band EQ, with presence, master volume and a chromatic tuner.

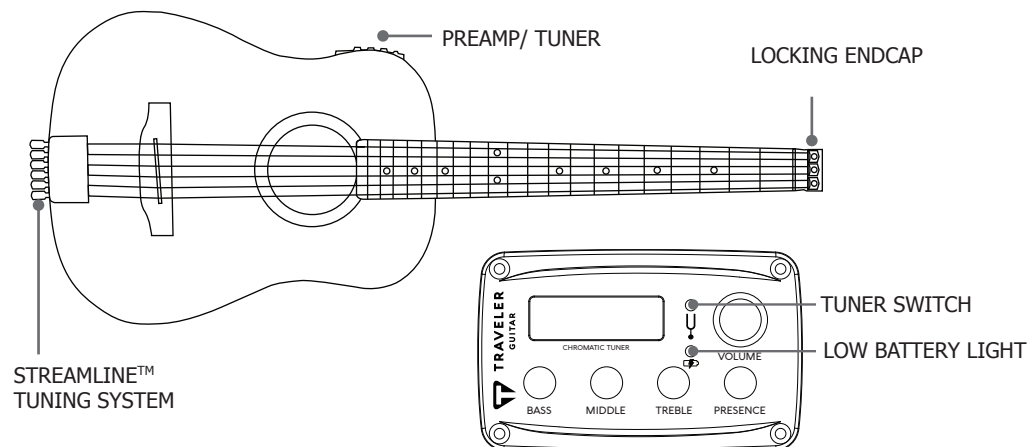

SETUP

Your new Redlands Dreadnought guitar will arrive ready to play. If your guitar is factory packed it will be wrapped in a thin, temperature insulating bag. This bag can be discarded. Also included are 1 medium allen wrench for loosening/tightening the locking endcap and 1 truss rod adjustment tool.

USING THE ELECTRONICS

The preamp features standard volume, treble, middle, bass and presence controls. Be sure to unplug all cables from your guitar when not in use to save battery life.

USING THE TUNER

Push the Tuner button to engage the electronic tuner (this mutes the signal going to the 1/4" output.) Play a single open string and the note name will appear on the LCD display. The screen shows a small meter which displays the string's tune. When pointing toward the left, the string is too low in pitch. When pointing toward the right, the string is too high in pitch. When pointing directly in the middle, the screen turns green and the string is in tune. The tuner works when the guitar is unplugged.

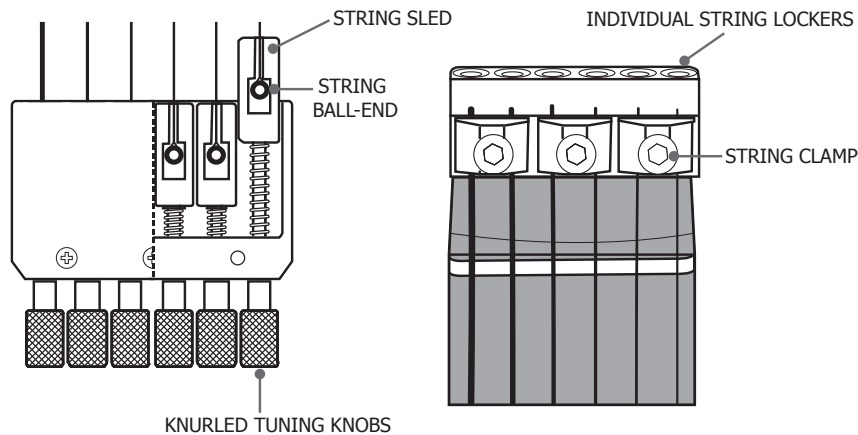

TUNING

The knurled tuning knobs on the Streamline™ tuning system raise and lower the pitch of the strings. They do not turn indefinitely. If too much resistance is met, the string may need to be re-installed or replaced in order to allow enough space for the tuning sled to move.

CHANGING STRINGS

The Redlands Dreadnought uses standard, ball-end strings. (Factory installed D'Addario EXP-16.) Only a single allen wrench (included) is required to change strings. We also recommend that you change the strings in pairs due to the string clamps.

First, loosen existing string by loosening the knurled tuning knob. This allows you to access the ball-end cavity of the string sled. Remove the old string then place the ball end of the new string in the cavity. Tighten the knurled tuning knob just enough that the ball end will not fall out of the sled. Now on the endcap loosen and remove the string clamp holding the old strings. Loosen the individual string locker. The old string can be pulled out and the new string can be fed through the hole in the endcap. Pull the string as tight as possible. Now tighten the individual string locker. Re-install the string clamp and tighten it. Any excess string can now be cut off. Tune to pitch.

CHANGING THE BATTERY

The "BATT LO" indicator will light when it's time to replace the batteries. The battery access port is next to the output jack for the guitar. Install a fresh 9 volt battery, paying attention to the +/- orientation.

CLEANING, STORAGE AND GENERAL CARE

Periodic cleaning and polishing will help protect your Traveler Guitar. Use a polish formulated for musical instruments and apply it according to the polish directions—or, you can wipe the guitar down with a clean, damp cloth followed quickly by a clean, dry cloth. To clean residue off the fingerboard, you can use extra-fine steel wool to rub up and down the length of the fingerboard over the top of the frets. Never use furniture polish on the guitar, as you may damage the finish.

When not in use, your Traveler Guitar should be stored in its included gig bag to protect it from exposure to the elements. Protect your guitar from extreme temperatures and changes in humidity. Never leave your Traveler Guitar in a closed vehicle or any other location where the guitar will be exposed to extreme heat. If you live in a very dry climate, you may want to use a guitar humidifier.

We recommend leaving complicated operations (such as truss rod adjustments) to a trained guitar technician. Improper truss-rod adjustments may damage your guitar and void your warranty.

The leather hang strap attached to your guitar's endcap was designed to aid in-store display, but it can also be used to hang your guitar from a wall mount or stand. Be sure your guitar is secure before walking away from it. If you wish, you can remove the strap by clipping the plastic tie with wire cutters. Be careful not to scratch the finish on the neck or endcap.